



translation of the original instructions for use (also applies to special designs)



BRANO a.s., 747 41 Hradec nad Moravicí
the Czech Republic
tel.: +420/ 553 632 303
<http://www.brano-zz.cz>; <http://www.brano.eu>
zz-info@brano.eu; info@brano.eu

INSTRUCTION MANUAL
SAFETY PRINCIPLES, OPERATION AND MAINTENANCE
FOR

TRAVELLING CHAIN BLOCKS

type Z220

modification according to the width of the running profile

– A, – B, – C

design for potentially explosive atmospheres – NEXP

lifting capacities

0,5t; 1t; 1,6t; 3,2t; 5t; 7,5t; 10t; 15t and 20t

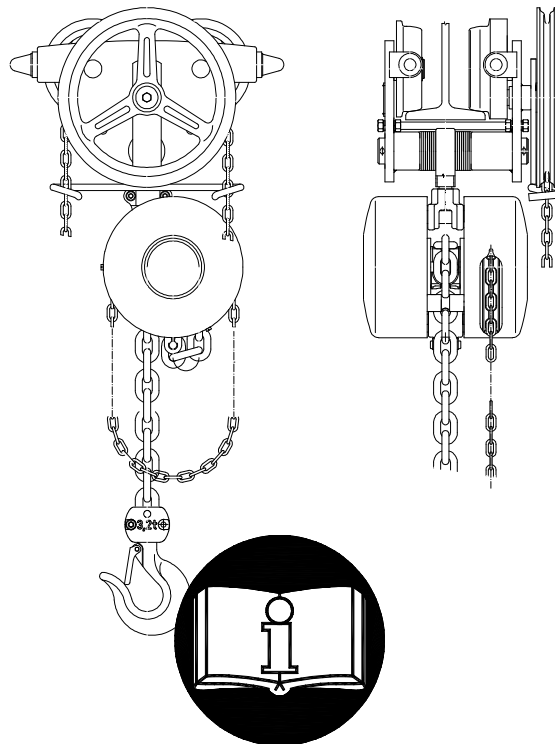

Read carefully this manual before using this product. This manual contains important information on use, safety, installation, operation and maintenance of the product.
Make this manual available to all responsible persons.

Keep for further use!

Edition 12th

May 2021

Evidence number 1-56802-0-0

CONTENT

1 DEFINITION	3
2 DEVICE PURPOSE	3
3 SAFETY PRINCIPLES	4
3.1 SAFETY SUMMARY	4
3.2 SAFETY PRINCIPLES	4
3.2.1 Prior to use	4
3.2.2 When in use	5
3.2.3 After use	5
3.2.4 Risk analysis	5
3.2.5 Maintenance	5
4 PACKING, STORAGE AND MANIPULATION	5
4.1 DELIVERY and PACKING	5
4.2 STORAGE	6
4.3 MANIPULATION	6
5 MAIN TECHNICAL PARAMETERS	6
5.1 MECHANICAL CLASSIFICATION	10
5.2 MATERIAL AND DESIGN	10
5.3 DATA ON PRODUCT	11
6 INSTALLATION OF THE CHAIN BLOCK	11
6.1 CHECKING BEFORE THE INSTALLATION	11
6.1.1 Load carrying structure	11
6.1.2 (crane) trolley beam track	11
6.2 ASSEMBLY OF THE CHAIN BLOCK	12
6.2.1 Condition for the correct travel of the trolley	12
6.2.2 Installation onto trolley beam track of lifting capacities 0,5t and 1t	12
6.2.3 Installation onto trolley beam track of lifting capacities 1,6t; 3,2t; 5t; 7,5t and 10t	13
6.2.4 Installation onto trolley beam track of lifting capacities 15 and 20t	13
6.2.5 Lubrication of the chain	13
6.2.6 Checking of the chain position	13
6.3 CHECK BEFORE USE	13
6.3.1 Setting of the hand chain	14
7 SERVICE AND OPERATION OF THE CHAIN BLOCK	14
7.1 USE OF THE CHAIN BLOCK	14
7.2 LIFTING, LOWERING	15
7.3 SAFETY WORKING ENVIRONMENT	16
8 INSPECTION OF THE CHAIN BLOCK	16
8.1 INSPECTION	16
8.1.1 Inspection classification	16
8.1.2 Daily inspection	17
8.1.3 Regular inspection	17
8.1.4 The chain block occasionally used	17
8.1.5 Inspection record	17
8.2 INSPECTION PROCEDURE	17
9 TROUBLE-SHOOTING	21
10 LUBRICATION	21
10.1 GENERALLY	21
10.2 GEARINGS	21
10.3 LOAD CHAIN	22
11 MAINTENANCE	22
11.1 SAFETY PRINCIPLES	22
11.2 REPLACEMENT OF THE LOAD CHAIN	22
11.2.1 Single fall chain	22
11.2.2 Multi-fall chain	22
11.3 BRAKE ADJUSTMENT	23
11.4 BEARINGS	23
11.5 GENERAL INSTRUCTIONS	23
11.6 CHECK	23
11.7 REPAIR	24
11.8 TEST	24
12 PUTTING OUT OF OPERATION – LIQUIDATION	24
13 RELATED DOCUMENTATION	24
14 FINAL REQUIREMENTS OF THE MANUFACTURER TO THE CUSTOMER	24

1 DEFINITION

! DANGER

Danger: is used to indicate the presence of hazard, which will cause death or severe injury, if the warning is ignored.

! WARNING

Warning: is used to indicate a possible hazard, which could cause death or severe injury, if the warning is ignored.

! CAUTION

Caution: is used to indicate a possible hazard, which could cause light injury, if the warning is ignored. Caution can warn against dangerous practices as well.

Lifting capacity (Q): indicates the maximum permitted mass of a load (working load limit), which a chain block is designed to support in general service under conditions defined in this manual.

2 DEVICE PURPOSE

2.1 The travelling chain block **type Z220** in any modification (-A, -B, -C, R) and designed for use in potentially explosive atmospheres **Z220-NEXP** (hereinafter referred to as product or **NEXP**= structurally identical product, differing in surface protection of selected parts, marking plate material and documentation) **of lifting capacities 0,5t, 1t, 1,6t, 3,2t, 5t, 7,5t, 10t, 15t, and 20t** has been designed solely for hand vertical lifting, lowering and moving of free loads in working area of travel under normal atmospheric conditions in the workplace. The load mass must not exceed the specified nominal lifting capacity.

2.2 The product has been designed in compliance with the requirements stipulated by Directive 2006/42/EC of the European Parliament and of the Council, as amended by the Czech technical regulation – Government Directive No. 176/2008 Coll., as amended, and the requirements of the harmonized Czech technical standards ČSN EN ISO 12100 and ČSN EN 13157+A1.

2.3 The product has been designed in compliance with the requirements stipulated by Directive 2014/34/EU of the European Parliament and of the Council, as amended by the Czech technical regulation – Government Directive No. 116/2016 Coll., as amended. The product has been designed as Ex **II2ExhIMb** equipment pursuant to ČSN EN ISO 80079-36:2016 and ČSN EN ISO 80079-37:2016. It complies with the conditions stipulated for use in mining environments classed as “hazardous atmospheric conditions 2” pursuant to ČSN EN 1127-2.

2.4 The product has been designed in compliance with the requirements stipulated by Directive 2014/34/EU of the European Parliament and of the Council, as amended by the Czech technical regulation – Government Directive No. 116/2016 Coll., as amended. The product has been designed as Ex **II2GExhIICT6Gb**, Ex **II2DExhIICT85°CDb** equipment pursuant to ČSN EN ISO 80079-36:2016 and ČSN EN ISO 80079-37:2016. It complies with the conditions stipulated for use in environments classed as „zone 1 and zone 21“, “ zone 2 and zone 22“ pursuant to ČSN EN 1127-1.

Note: Articles 2.3 and 2.4 apply to NEXP product design.

3 SAFETY PRINCIPLES

3.1 SAFETY SUMMARY

Danger exists when lifting and travelling with loads, particularly when the chain block is not used properly or is poorly maintained. Since an accident or serious injury could result, special safety precautions apply to the operation with the chain block during its assembly, maintenance and inspection.

! WARNING

NEVER use chain block for lifting and transporting people.

NEVER lift or transport loads over or near people.

NEVER load the chain block more than the lifting capacity shown on the chain block nameplate.

ALWAYS make sure the load carrying structure will provide adequate support to handle fully loaded chain block and all the lifting operations.

ALWAYS let people around to know when a lift is about to begin.

ALWAYS read instruction manual and safety instructions.

Remember proper that rigging, lifting and pulling techniques are the responsibility of the operating staff. Therefore check all applicable national directions, regulations and standards for further information on the safety use of your chain block.

3.2 SAFETY PRINCIPLES

! WARNING

3.2.1 Prior to use

ALWAYS ensure, physically fit, qualified and instructed persons over 18 years of age, familiarized with this manual and trained in safety conditions and way of work, operate the chain block.

ALWAYS check the chain block daily before use according to the section 8.2.(1) „Daily inspection“.

ALWAYS make sure the ends of track are fitted with the end stops.

ALWAYS make sure the track is free from any object.

ALWAYS make sure the length of chains is long enough for the intended job.

ALWAYS check the brake function of the chain block before use.

ALWAYS use original chain only.

ALWAYS ensure the load chain is not corroded, is cleaned and oiled.

ALWAYS make sure the last link of load chain is strongly fastened to the body.

NEVER use damaged or worn out chain block.

NEVER use chain block with jumped out, damaged or missing hook's safety latch.

NEVER connect or lengthen the load chain.

NEVER use a chain block without a visible marking of the lifting capacity.

NEVER use modified or deformed hooks.

NEVER use a chain block marked by the label „**OUT OF OPERATION**“.

ALWAYS consult the manufacturer or his authorized representative, if you plan to use a chain block in non-standard or extreme environments.

ALWAYS check that the product is grounded through the ground terminal when working in an explosive atmosphere

ALWAYS wipe off any dust before handling the product in an explosive atmosphere

3.2.2 When in use

ALWAYS	make sure the load is properly seated in the hook.
ALWAYS	make sure the safety latches of hooks work in the correct way.
ALWAYS	pay attention to the limit positions.
ALWAYS	use manual power only.
ALWAYS	when lifting loads approaching the nominal lifting capacity of the lifting device, we recommend, regarding the operating forces, the operation was ensured by two persons.
NEVER	use a chain block for tensioning, pulling or anchoring loads.
NEVER	connect or lengthen the load chain.
NEVER	allow swinging the load, causing impacts or vibrations.
NEVER	use a chain as a sling.
NEVER	load the chain block by diagonal pull.
NEVER	hitch a load on the tip of the hook.
NEVER	pull the chain over any edge.
NEVER	weld, cut or make any operation on a suspended load.
NEVER	use a chain as a welding electrode.
NEVER	operate a chain block, if chain is jumping or atypical or excessive noise occurs.

3.2.3 After use

NEVER	leave a load suspended.
ALWAYS	ensure the chain block against incompetent use.

3.2.4 Risk analysis

The analysis of possible risks in light of design, operation and environment of the chain block application is presented in freestanding document „Risk analysis“. This document can be required in service centers.

3.2.5 Maintenance

ALWAYS	enable qualified persons inspect the chain block regularly.
ALWAYS	ensure the chain was clean and oiled.
ALWAYS	ensure the sliding parts were greased enough (except the brake).
NEVER	add other parts for lengthening the load chain

Only such interventions can be done when maintaining that are in compliance with requirements of the manufacturer specified in the chapters 11 and 14 of this manual.

IT IS NOT PERMISSIBLE to carry out repairs and maintenance in other way than prescribed by the manufacturer. It concerns namely the forbiddance of using of unoriginal spare parts or carrying out modifications on the product without an approval of the manufacturer.

4 PACKING, STORAGE AND MANIPULATION

4.1 DELIVERY and PACKING

4.1.1 Travelling chain blocks are supplied free loaded on pallets wrapped in foil, trolley and chain block separately. Chains are ensured against unfolding by the wire.

4.1.2 The following accompanying documentation is a part of the delivery:

- a) Instruction Manual
- b) EC Declaration of Conformity
- c) Certificates of Quality and Completeness and Guarantee Card.
 - c1) Guarantee period is stated in the Guarantee Card.

- c2) The guarantee does not apply to defects caused by infringement of the instructions stated in this Instruction Manual and defects occurred owing to improper use and unskilled intervention.
- c3) The guarantee does not apply also to modifications on the product or using of unoriginal spare parts without an approval of the manufacturer.
- c4) A claim for defects in the product must be applied according to the relevant provisions of the Commercial Code or the Civil Code, as amended.
- d) List of service centers (for the Czech and Slovak Republics only).

4.2 STORAGE

Store the traveling chain blocks in dry and clean stocks free from chemical influences and vapours.

- (1) Always store the chain block without any suspended load.
- (2) Remove all dust, water and impurities from the chain block.
- (3) Lubricate chain, pivots of pulley, pivots of hook and spring of safety latch of hook.
- (4) Store the chain block in a dry place.
- (5) During further use follow instructions of the article No. 8.1.2 „Daily inspection” or 8.1.4 „The traveling chain block occasionally used“.

4.3 MANIPULATION

During transportation and manipulation follow the applicable technical regulations and standards for work with heavy loads.

5 MAIN TECHNICAL PARAMETERS

LIFTING CAPACITIES 0,5t; 1t; 1,6t; 3,2t and 5t

Table 5.A - Technical parameters

Type	Lifting capacity (t)	Number of load chain falls	Chain ČSN EN 818-7 (strength class 8)	Operating force for travel (N)	Operating force for lift (N)	Travel ¹⁾ speed (m/min)	Lifting ¹⁾ speed (m/min)	Range of operating temperature	Lift (m)	Weight (kg)
Z220-A	0,5	1	Ø5x15	250	300	4,8	1,1	-20 °C Up to +50 °C	3	16,9
Z220-B										18,6
Z220-C										19,6
Z220-A	1		Ø7x21	250	350	4,8	0,7			22,4
Z220-B										24,1
Z220-C										25,1
Z220-A	1,6		Ø9x27	150	320	2,25	0,36			44,4
Z220-B										46,2
Z220-C										47,4
Z220-A	3,2		Ø11x31	280	400	2,3	0,29			73,1
Z220-B										74,9
Z220-C										76,6
Z220-A	5	2		350	400	1,8	0,145	105,5		
Z220-B								107,5		
Z220-C								110,8		

Notes:

- 1) Calculated on presumption of winding off 30m of the hand chain per minute.
- 2) Maximum standard lift is 15m. Required lift is necessary to be specified in the order.
Lifts exceeding 15 m must be consulted with the manufacturer.

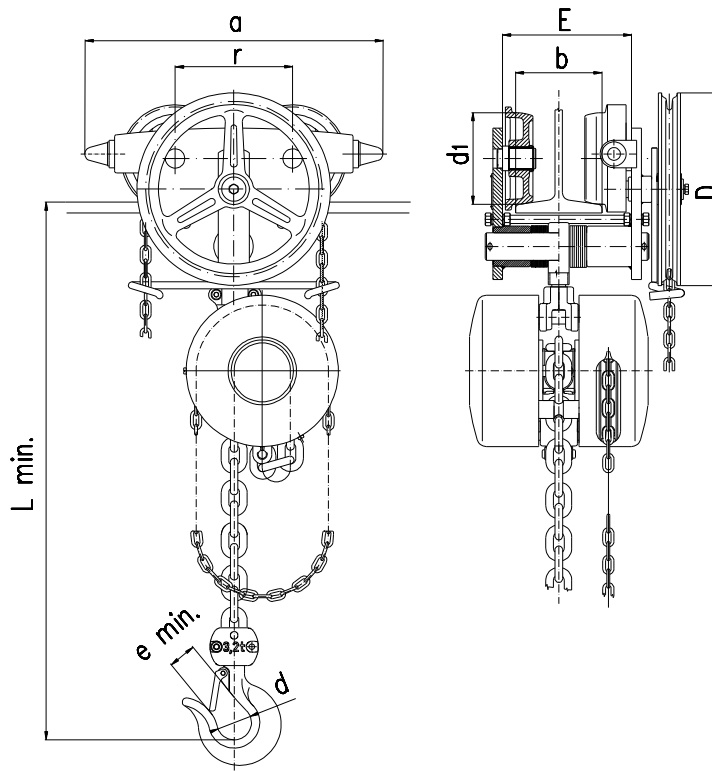

Table 5.B - Dimensions

Type	Lifting capacity (t)	Main dimensions – informative (mm)							I – beam (I, IPE, HEA, HEB, HEM)		
		a	d	d ₁	D	e _{min}	L _{min}	r	E	b	R
Z220-A	0,5 Is not suitable for the profile HEM	245	30	55	108	18,5	290	87	89 - 144	58 - 113	1000
Z220-B									89 - 253	58 - 226 (IPE, HEA, HEB) 58 - 155 (I - diagonal flange)	
Z220-C									199 - 327	125 - 300 (IPE, HEA, HEB) 125 - 155 (I - diagonal flange)	
Z220-A	1 Is not suitable for the profile HEM	245	36	55	108	23,5	340	87	89 - 144	58 - 113	1000
Z220-B									89 - 253	58 - 226 (IPE, HEA, HEB) 58 - 155 (I - diagonal flange)	
Z220-C									199 - 327	125 - 300 (IPE, HEA, HEB) 125 - 155 (I - diagonal flange)	
Z220-A	1,6	350	43	100	230	29,5	457	140	148 - 172	58 - 113	1700
Z220-B									148 - 284	58 - 226	
Z220-C									227 - 358	137 - 300	
Z220-A	3,2	435	50	133	280	35,5	515	170	168 - 187	82 - 125	2500
Z220-B									168 - 288	82 - 226	
Z220-C									246 - 362	160 - 300	
Z220-A	5	505	56	148	345	39,5	660	218	183 - 214	90 - 137	2800
Z220-B									183 - 304	90 - 226	
Z220-C									263 - 378	170 - 300	

Travelling chain blocks with great length of lift can be equipped upon special request with a chain container

LIFTING CAPACITIES 7,5t and 10t

Table 5.C - Technical parameters

Type	Lifting capacity (t)	Number of load chain falls	Chain ČSN EN 818-7 (strength class 8)	Operating power for travel (N)	Operating power for lift (N)	Lifting ¹⁾ speed (m/min)	Range of operating temperature	Lift (m)	Weight (kg)
Z220	7,5	2	Ø11x31	500	480	0,15	-20°C up to +50°C	3	207,2
Z220-C									211,2
Z220	10	3		500	390	0,1			264,5
Z220-C									272

Notes:

- 1) Calculated under presumption of unwinding 30m of hand chain per minute.
- 2) Maximum standard lift is 15m. The required lift is necessary to be specified in the order. Lifts over 15 m must be consulted with the manufacturer.

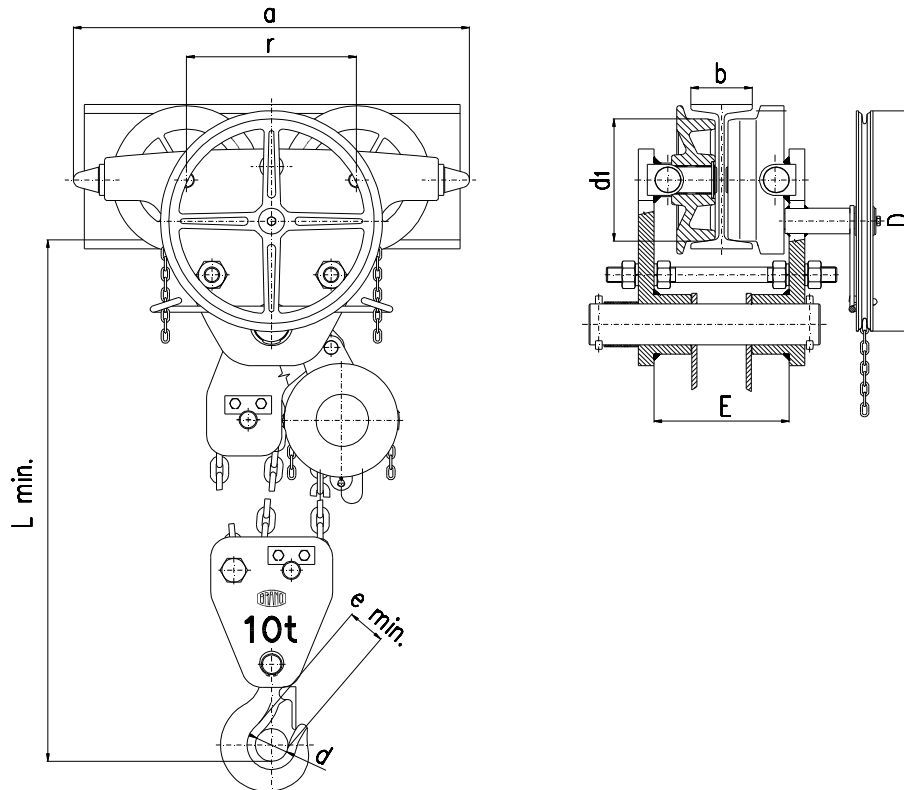

Table 5.D - Dimensionsy

Type	Lifting capacity (t)	Main dimensions – informative (mm)							I – beam (I, IPE, HEA, HEB, HEM)		
		a	d	d ₁	D	e _{min}	L _{min}	r	E	b	R
Z220	7,5	685	56	196	345	43	875	300	242 - 314	125 - 185	5000
Z220-C									263 - 429	146 - 300	
Z220	10	765	63	228	428	47	920	328	259 - 327	125 - 185	9000
Z220-C									314 - 442	180 - 300	

Travelling chain blocks with great length of lift can be equipped upon special request with a chain container.

LOAD CAPACITIES 15t and 20t

Table 5.E - Technical parameters

Type	Lifting capacity (t)	Number of load chain falls	Chain ČSN EN 818-7 (strength class 8)	Operating power for travel (N)	Operating power for lift (N)	Lifting ¹⁾ speed (m/min)	Range of operating temperature	Lift ²⁾ max. (m)	Weight without chain (kg)	Increase in weight per 1m of lift (kg)
Z220	15	4	Ø11x31	500	480	0,15	-20°C to +50°C	12	285	13
	20	6		500	400	0,1		8	345	19,2

Notes:

- 1) Calculated under presumption of unwinding 30m of hand chain per minute on each chain block.
- 2) Lift according to the order. Lifts over the values stated in the table must be consulted with the manufacturer.

Table 5.F - Dimensions

Lifting capacity (t)	Main dimension – informative (mm)							
	a	d	d ₁	D	r	f	e _{min}	L _{min}
15	1290	71	196	375	300	270	50	780
20	1500	80	237	428	328	380	62	720

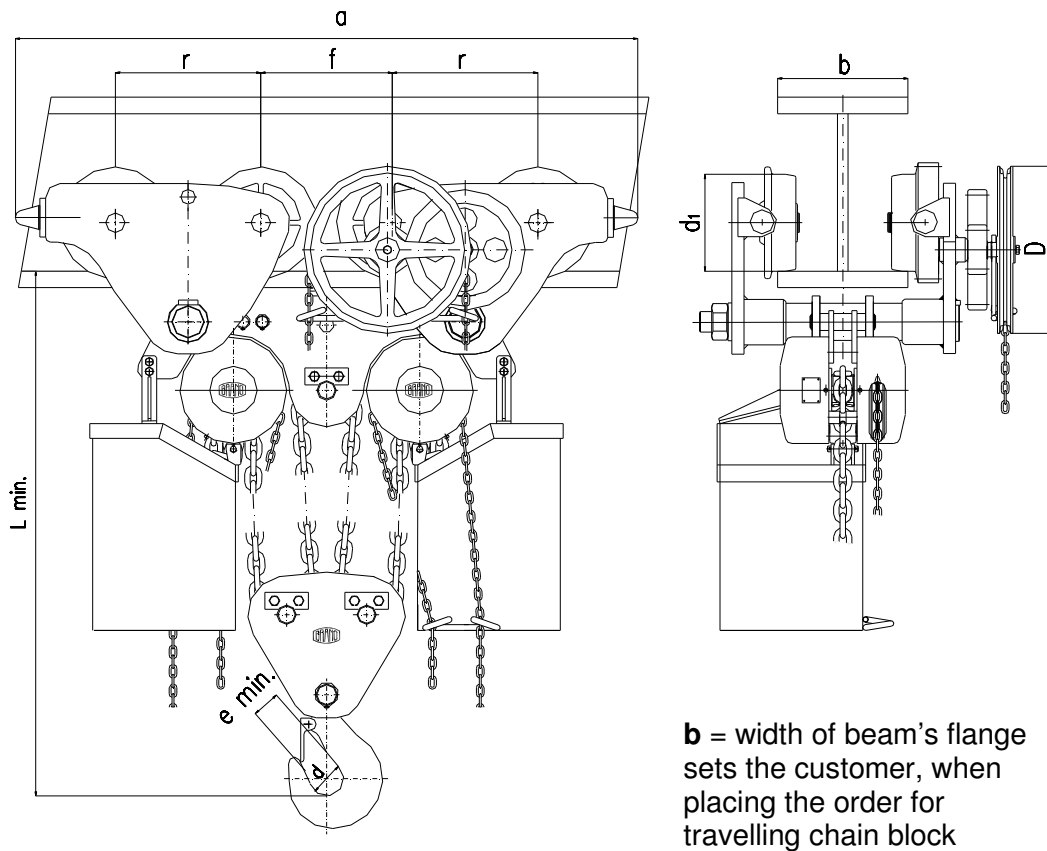

Travelling chain blocks of lifting capacities 15 and 20t are usually equipped with chain containers and are designated just for assembly to beams with flat flange. The possibility of track curving is not supposed.

5.1 MECHANICAL CLASSIFICATION

Safety and life of the travelling chain block is guaranteed under presumption it works in accordance with the specified classification. The travelling chain block is designed for the class 1Bm according to the regulation FEM 9.511 – see TABLE 5.1. (conforms to classification of the mechanism M3 according to the ISO 4301/1).

Average daily operating time is set by loading diagram.

Tab. 5.1 MECHANICAL CLASSIFICATION

Load spectrum diagram (load distribution)	Definition	Cubic mean value	Average daily operating time (h)
1 (light)	Travelling chain blocks usually subject to very small loads and in exceptional cases only to maximum loads.	$k \leq 0,50$	1 - 2
2 (medium)	Travelling chain blocks usually subject to small loads but rather often to maximum loads.	$0,50 < k \leq 0,63$	0,5 - 1
3 (heavy)	Travelling chain blocks are usually subject to medium loads but frequently to maximum loads.	$0,63 < k \leq 0,80$	0,25 – 0,5
4 (very heavy)	Travelling chain blocks are usually subject to maximum or almost maximum loads.	$0,80 < k \leq 1,00$	0,12 – 0,25

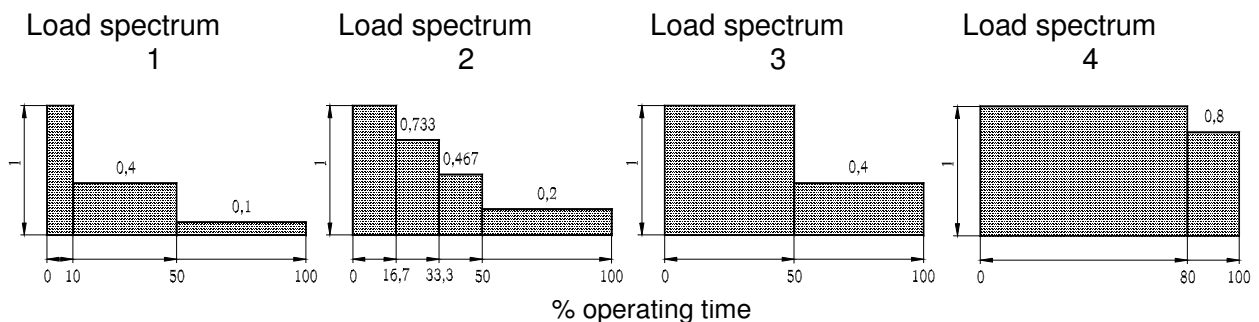

5.2 MATERIAL AND DESIGN

5.2.1 Main parts of the chain block are manufactured from steel and cast iron, braking inserts of brake from brass or ceramic-metallic material.

5.2.2. Materials inclinable to creation of an incendiary spark in terms of the annex No. 2 article 1.3.1 to the ministerial order No. 116/2016 of the Coll. of Laws and the ČSN EN 1127-2 article 6.4.4 and ČSN EN ISO 80079-36 article 6.4.2.1 harmonized technical standards are not used.

5.2.3 Materials with dangerous effects of static electricity within the meaning of the ČSN EN 1127-2 article 6.4.7, ČSN EN ISO 80079-36 article 6.7 and ČSN CLC/TR 60079-32-1 are not used in the chain block.

5.2.4 The chain block does not exceed the noise values specified in the annex 1 article 1.7.4.2 letter u of the MO No. 176/2008 of the Coll. of Laws (EP and RE directive No. 2006/42/EC)

Note: Articles 5.2.2 and 5.2.3 apply to NEXP product design.

5.3 DATA ON PRODUCT

Every product is fitted with label with specified data as follows:

Standard design:	NEXP product design:
Manufacturer's identification	Manufacturer's identification
Address of the manufacturer	Address of the manufacturer
Type of product	Type of product
Lifting capacity	Lifting capacity
Serial number	Serial number
Year of production	Year of production
CE marking	CE marking
	sign of protection type (I <i>IM2ExhIMb</i> for group I, <i>I12GExhI1CT6Gb</i> , <i>I12DExhI1CT85°CDb</i> for group II)

6 INSTALLATION OF THE CHAIN BLOCK

6.1 CHECKING BEFORE THE INSTALLATION

Prior to installation check the chain block for possible damages.

The NEXP product must be installed in such a way as to prevent creeping charges. Charging mechanisms stronger than manual friction must be avoided at the installation site.

A NEXP product when used in a mine or other environment where the product could collide with falling, flying... objects (rock, stones...) must be protected to minimize the likelihood of a collision (sufficiently dimensioned cover, ...).

6.1.1 Load carrying structure

The (crane) trolley beam track and related load carrying structure (parts of buildings, etc.) determined for operation of the travelling chain block shall be supported by drawings and static calculation.

! WARNING

ALWAYS make sure the trolley beam track and related load carrying structure is firm enough to support the weight of the load and the travelling chain block. The installation must not be provided onto the structure, where carrying capacity cannot be checked.

ALWAYS make sure the ends of travel rail are fitted with end stops.

ALWAYS make sure the flatness of the trolley beam track is kept.

ALWAYS the user is responsible for the load carrying structure!

6.1.2 (crane) trolley beam track

! CAUTION

The travelling chain block can be installed to beams with inclination of the lower flange to 20% or with a straight flange. At lifting capacities 15 and 20t only to the straight flange.

Range of width of lower flange of beam (b) and minimum radius of curve of the trolley beam track (R) for particular lifting capacities are mentioned in the table 5 - Dimensions. At lifting capacities 15 and 20t the curve of the trolley beam track is not permitted.

! WARNING

The permissible maximum deflection of the trolley beam track from loading by own mass and nominal loading capacity is 1/500 of distance between suspending (supports).

Permitted maximum gradient of running surface is 0,3%.

Maximum height of the trolley beam track above the floor is 20m. An application of the chain block on higher trolley beam tracks is necessary to be consulted with the manufacturer.

6.2 ASSEMBLY OF THE CHAIN BLOCK

! CAUTION

Be careful during suspending the chain block on the suspension element and ensure appropriate conditions for safety installation according to the character of the environment (working platform, auxiliary lifting device, etc.) to avoid endanger or injury of people. Use safety equipment, when suspending the chain block in heights to avoid fall from heights.

User is responsible for creating conditions for installations and providing installation of the chain block.

! WARNING

Assembly of the chain block of lifting capacities 7,5t and 10t can be provided only by qualified persons.

User is responsible for creating conditions for assembly and providing assembly of the chain block.

Assembly of the chain block of lifting capacities 15t a 20t can be provided only by specialized factory-authorized firm.

6.2.1 Condition for the correct travel of the trolley

A) Tolerance (x) between tyres of travelling wheels and flange of beam shall be approximately 2 mm. For curvature tracks the tolerance must be increased adequately.

B) Suspension shackle of the trolley must be in the centre of the beam.

C) Attachment bolts (at capacities 1,6 – 10t) place to centres of openings in sides in such a way, the condition of tolerance between the bolt and lower flange of beam was 3 - 6mm was fulfilled.

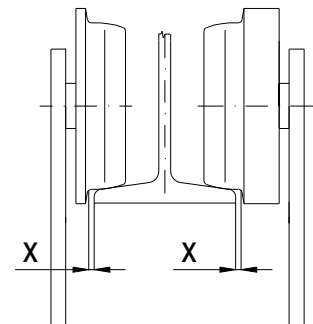

6.2.2 Installation onto trolley beam track of lifting capacities 0,5t and 1t

- 1) Remove the retaining rings from the crossbar, remove distance washers and pull out the crossbar from side plates of the trolley. This will cause disconnection between the chain block and trolley. Take off distance washers and lifting loop with the chain block.
- 2) Put on the lower flange of I – beam side plate with geared wheels and hand chain wheel and ensure against the possible fall.
- 3) Insert the crossbeam into side plate bushing and ensure by the cotter pin.
- 4) Set on the crossbeam the relevant number of distance washers so that the chain block was placed in axe of the beam and the condition for the correct function was thus fulfilled according to the 6.3.1.
- 5) Set on the crossbeam the lifting loop with the chain block.

- 6) The same number of distance washers set on the other side of the lifting loop (sheave fork).
- 7) Put on the lower flange of I – beam the other side plate and set on the cross beam all remaining distance washers and ensure by cotter pin.
- 8) Stretch ends of both cotter pins so that they cannot fall out. Straighten hand chain and test rail of travelling chain block without the load.

6.2.3 Installation onto trolley beam track of lifting capacities 1,6t; 3,2t; 5t; 7,5t and 10t

- 1) Remove the cotter pins from the crossbeam, take off the distance washers and move the cross beam out of the side plates of the trolley. Thus you disconnect the chain block and trolley. Take off the distance washers and lifting loop with the chain block.
- 2) Screw off outer nuts of distance bolts of the trolley and dismantle side plate of trolley on side without geared wheels.
- 3) Put on the lower flange of I – beam the side plate with geared wheels and hand chain wheel and ensure against the possible fall.
- 4) Put the other side plate of the trolley on the flange of beam and distance bolts and ensure with nuts of the distance bolts to prevent fall of the trolley from the beam.
- 5) Insert the crossbeam into side plate bushing with plain wheels.
- 6) Set on the crossbeam the relevant number of distance washers so that the chain block is placed in axe of the beam and the condition for the correct function was thus fulfilled according to the 6.3.1.
- 7) Set on the crossbeam the lifting loop with the chain block.
- 8) The same number of distance washers set on the other side of the sheave fork.
- 9) Put the crossbeam into bushing of the other side plate and ensure by the cotter pin.
- 10) All remaining distance washers put on the crossbeam out of the side plate with plain wheels and ensure by cotter pin.
- 11) Stretch ends of both cotter pins so that they cannot fall out once. Straighten hand chain and test the rail without the load.

6.2.4 Installation onto trolley beam track of lifting capacities 15 and 20t

The installation requires special assembly jigs and can be performed only by a specialized factory-authorized firm.

6.2.5 Lubrication of the chain

Put the thin layer of oil on the chain preferably by means of a spray. Regular lubrication will avoid wear and corrosion of the chain and lengthen its life.

6.2.6 Checking of the chain position

Check, whether the hook is not turned over and chain kinked or twisted as illustrated in the pictures 1 and 2. If the chain is kinked, return it to the correct position. Never suspend load onto kinked or twisted chain. Chain is not kinked, if the welded parts of links are in one row.

It applies for lifting capacities 5t and more. Pay increased attention to checking of the chain position of lifting capacities 15 and 20t.

Pic. 1 Kinked chain

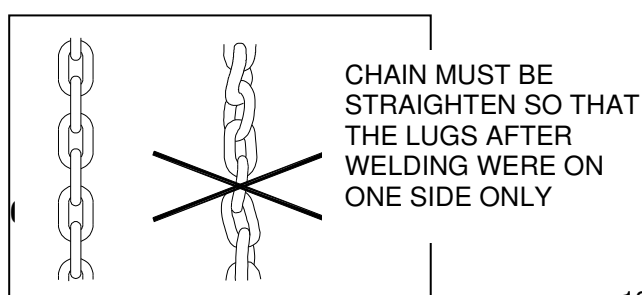

Pic. 2 Chain twisting

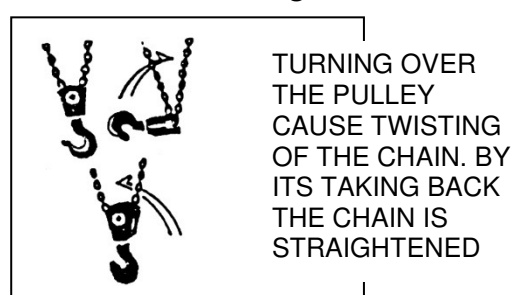

6.3.1 Setting of the hand chain

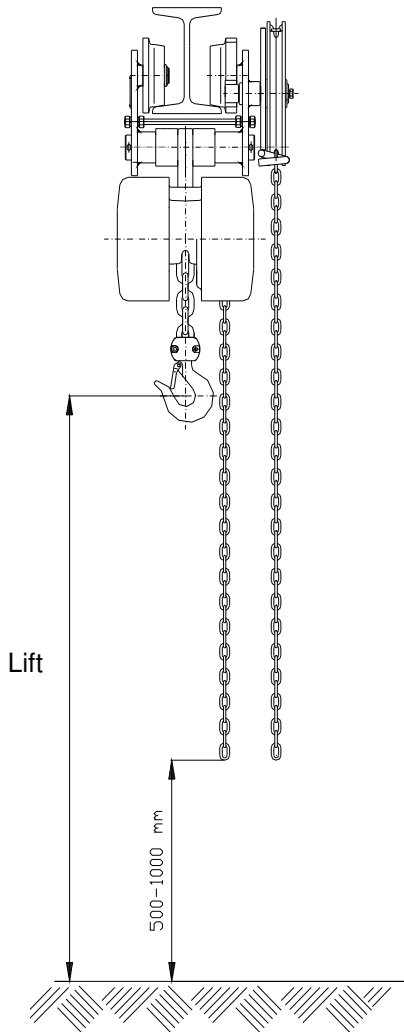

After the installation of the chain block in the workplace we check the position of the hand chain. The distance of the end of bottom loop of the hand chain over the level of the surface, on which operation staff of the chain block stands during the operation, must be in the range 500 –1000mm. Chain blocks are supplied with hand chains, the length of which is proportional to the lift of the chain block and during the standard installation meets condition of correct setting of the chain end.

In other cases, where regarding the way of use of the chain block, the length of the hand chain does not meet prescribed conditions, the chain must be shortened or lengthened.

Shortening of the chain: we disconnect the chain in place of the coupling link by buckling free ends of the links. We shorten the chain by required length and connect again by coupling link. Free ends of the coupling link we bend to one another.

Lengthening of the chain: we disconnect the chain in place of the coupling link by buckling free ends of the links. We attach other part of chain of required length by means of two coupling links. Free ends of coupling links we bend to one another.

Coupling links and hand chain of required length can be bought as spare parts.

Note: the requirement for hang chain of other length than standard one can be given just in the order.

! CAUTION

- (1) First see again through the previous articles of this manual and make sure all steps were correctly done and all parts are safely assembled.
- (2) Check over visually, whether the load carrying structure or pendant elements are without defects.
- (3) By pulling the hand chain of the chain block check the function of the travelling chain block without any load.
- (4) By pulling the hand chain of the trolley check the travel of the chain block.
- (5) Provide several lifting and lowering with a suitable load (10% to 50% of lifting capacity). At the same time, check the brake, whether it holds the load without slipping during lowering and stopping.

7 SERVICE AND OPERATION OF THE CHAIN BLOCK

7.1 USE OF THE CHAIN BLOCK

The travelling chain block is the multipurpose device, determined for lifting and lowering of loads and horizontal movement of loads in working space of the crane track under normal atmospheric conditions in the workplace and in environments with an explosive risk as well, if there is a symbol of the protection type on the label – see articles 2.3 and 2.4 of this instruction manual.

It is operated by means of hand chains. It is determined for organisations and private persons as well.

When installed outside, protect the chain block against the direct climatic influences.

! WARNING

Since work with heavy loads may present an unexpected danger, it is necessary to follow all the "Safety instructions" according to the chapter 3.

! WARNING

The last link of the load chain is anchored on the body of the traveling chain block. The anchorage just prevents against release of the load chain and is not determined for holding load.

Do not continue to work if tensioning of the anchored end of the load chain takes place. Any damage of the anchorage can cause fall of the load.

! WARNING

The covers of the hoist body are not sufficiently dimensioned in terms of "breakthrough", therefore any covers that could cause a collision with the gears must be repaired or replaced. If it happens that the product has a collision with a falling, flying object (rock slide) that could sufficiently damage the covers, work must be stopped immediately and the product inspected.

7.2 LIFTING, LOWERING

Lifting and lowering is provided by pulling the hand chain of the chain block. Lifting and lowering can be interrupted in any height of lift.

! WARNING

At chain blocks with a great lift (15 m and more) a danger of heating of the brake can happen when lowering load in exceptional cases (uninterrupted and quick lowering). In such cases it is necessary to lower loads slowly and step-wise).

! CAUTION

When lifting loads that will be in the lifted state handed over to other lifting device (crane, lift truck etc.) it is necessary to relieve the load chain (chains) of the chain block by means of the hand chain, not by lifting load by means of the other lifting device. Just defined procedure guarantees the trouble free release of the brake of the chain block after taking of the load.

! WARNING

Travelling chain blocks of lifting capacities 15t and 20t are determined for multimember operating staff. Speed of unwinding of chain during lifting or lowering has to be the same on both chain blocks – synchronised so that the same length of chain remain in both containers. The operating staff must check straightening of colour marked parts of the central part of the chain on the block (Z220/20t) or at the top pulley (Z220/15t) - see pic. 7.2.

Z220/20t

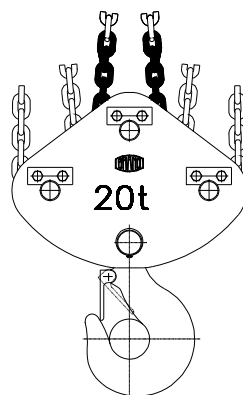

Z220/15t

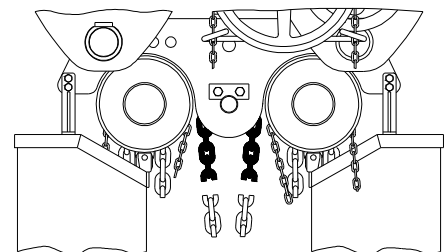

Pic. 7.2

7.3 SAFETY WORKING ENVIRONMENT

! WARNING

- (1) The operating staff must be demonstrably familiarized with this manual, must follow safety and hygienic regulations and must be authorized to the operation of this equipment.
- (2) The operating staff must be equipped with helmet, gloves and suitable footwear.
- (3) Only verified binding means of appropriate lifting capacity are to be used for binding loads.
- (4) When more persons take part in the operation, only one of them must be determined who is trained in safety work instructions and responsible for manipulation with the travelling chain block.
- (5) He must have a clear and unobstructed view of the working area before starting the work. When it is not possible, one or more persons must help to supervise in the nearby area of the chain block.
- (6) The operating staff must check, whether the entire work place is safe and whether there is a possibility of escaping from this area in case of endanger, before starting to operate the chain block.
- (7) The free space for the operating staff shall be ensured when using the travel of the chain block.
- (8) During the work with the chain block the suitable distance of the operating staff from the load must be kept. It is prohibited to lift or lower bulky loads preventing to keep sufficient distance.
- (9) When operating the chain block in limited areas you must prevent the hook or load would not hit into obstacles or to the chain block body.

8 INSPECTION OF THE CHAIN BLOCK

8.1 INSPECTION

8.1.1 Inspection classification

- (1) Initial inspection: it precedes prior to initial use. All new or repaired travelling chain blocks shall be inspected by a designated qualified person to ensure qualified compliance with the applicable provisions of this manual.
- (2) Inspections of chain blocks in regular service are generally divided into two classifications according to intervals at which should be performed. The intervals depend upon the nature of the critical components of the chain block and the degree of their exposure to wear, deterioration or malfunction. The two general classifications are herein designated as daily and regular. The respective intervals are defined as follows:

(a) Daily inspection: visual inspection provided by the operating staff designed by the user at the beginning of each usage.

(b) Regular inspection: visual inspection provided by the qualified person designated by the user.

- 1) normal operation – annually,
- 2) heavy operation – twice per year,
- 3) special or infrequent operation – as recommended by a qualified person at first usage and according to the directions of the qualified employees (maintenance workers).

8.1.2 Daily inspection

Check, at parts such as those listed in section 8.2(1) "Daily inspection", whether chain blocks are not damaged or are without any defect. Provide this inspection also during the operation in the interval between regular inspections. Qualified employees shall determine, whether any defect or damage can constitute a hazard or more detailed inspection is required.

8.1.3 Regular inspection

Complete inspections of the travelling chain block perform as recommended regular inspections. These inspections may be performed with the travelling chain block in its normal location and do not require dismantling the chain block. The recommended regular inspection defined in the section 8.2(2) shall be performed under the supervision of competent persons who determine, whether the complete disassembly is necessary. These inspections shall include the requirements of the daily inspection as well.

8.1.4 The chain block occasionally used

(1) The chain block that has been idle for a period of one month or more but less than one year shall be put through a detailed inspection conforming to the requirements of the section 8.1.2 before it is placed again in operation.

(2) The chain block that has been idle for a period of one year shall be put through a detailed inspection conforming to the requirements of section 8.1.3 before it is placed again in operation.

8.1.5 Inspection record

Always keep the record on the performed tests, repairs, inspections and maintenance of travelling chain blocks. Dated inspection records should be performed at time intervals specified in sections 8.1.1 (2) (b) and such records are stored available in the place designated by the user. Defects found by the inspection or recorded during the operation must be announced to the person responsible for safety and designated by the user.

8.2 INSPECTION PROCEDURE

(1) **Daily inspection** (provided by the operating staff or competent person)

PART	INSPECTION METHOD	LIMIT/CRITERIA FOR DISCARD	REMEDY
1. Function of chain block.	Visually, by listening.	Chain binds, jumps, make an excessive noise, etc.	Clean and lubricate the chain, if the problem is not solved, replace the chain.
2. Fastening parts.	Visual check of all bolts, nuts, rivets etc.	Defective or missing parts. Released parts.	Replace by new ones. Tighten released parts.

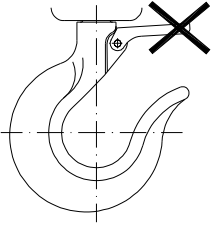
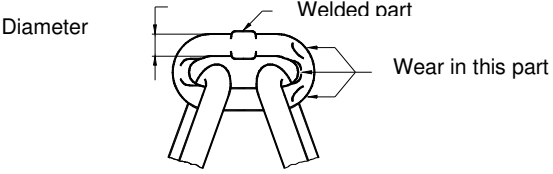
<p>3. Hooks (1) Appearance</p> <p>(2) Hook rotation</p> <p>(3) Safety latch</p>	<p>Visually.</p>  <p>Turn the hook around its axis.</p> <p>Manual springing of safety latch</p>	<p>Safety latch jump out from the hook top. Bent shank of the hook, other visible hook deformations.</p> <p>Hook does not rotate fluently or scrub.</p> <p>Safety latch does not return after pushing</p>	<p>Professional inspection of lifting device – replacing the hook and other damaged parts.</p> <p>Clean and lubricate.</p> <p>Clean, lubricate, repair or replacement</p>
<p>4. Load chain (1) Appearance</p>	<p>Check visually the whole chain.</p>	<p>Cracks in the place of welding, deformation, excessive wear, corrosion.</p>	<p>Chain replacement.</p>
<p>Note: The complete wear of the chain cannot be determined by the visual inspection. When wear sign is found check the chain according to “Regular inspection”.</p>			
<p>(2) Lubrication</p> <p>(3) Setting of chain</p> <p>(4) Overturning of pulley (valid only for two strand models).</p>	<p>Visually</p> <p>Visual inspection according to the picture 1, whether the chain is not twisted.</p> <p>Visually according to the picture 2.</p>	<p>The chain is not lubricated.</p> <p>Chain is turned over or twisted, welds are not in line.</p> <p>Chain is twisted by overturning of pulley, welds are not in line.</p>	<p>Clean and lubricate the chain.</p> <p>Straight up the chain and set to normal position.</p> <p>Straight up the chain by overreturning the pulley to the correct position.</p>
<p>5. Hand chain</p>	<p>Visually</p>	<p>Chain is overturned or twisted.</p> <p>Chain is deformed or damaged and do not enter correctly the chain wheel.</p>	<p>Straight up the chain and set it to normal position.</p> <p>Replace the chain.</p>
<p>6. Trolley side plate</p>	<p>Visually</p>	<p>Visible deformation of the side plate.</p>	<p>Replace of the side plate.</p>

(2) **Regular inspection** (provided by qualified person)

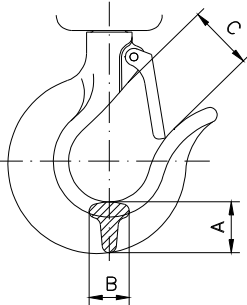
PART	INSPECTION METHOD	LIMIT/CRITERIA FOR DISCARD	REMEDY																																																																	
1. Fastening parts.	Visual check of all bolts, nuts, rivets, etc.	Defective or missing parts. Released parts.	Replace by new ones. Fasten released parts.																																																																	
2. All parts	Visual check.	Worn or damaged parts. Dirty and non lubricated parts.	Replace by new ones. Dismount, clean, lubricate and assemble again.																																																																	
3. Name plate – marking of the lifting capacity on the chain block	Visual check	Lifting capacity is illegible	Repair or replace by the new one. Repair marking on the chain block.																																																																	
4. Hooks (1) Deformation of hook (opening) (2) Wear of hook	Measure dimension „C“ by slide calliper. Visual check. Measure dimension „A“ and „B“ by slide calliper.	Measured value is higher than set by table. Deformation is visible during visual check. Do not use hook., if the dimensions „A“ or „B“ get smaller about more than 10%.	Qualified check of lifting device – replacement of hooks and other damaged parts. Replace worn out or deformed hook by a new one.																																																																	
		<table border="1"> <thead> <tr> <th rowspan="2">Capacity (t)</th> <th colspan="2">Dimension "A" (mm)</th> <th colspan="2">Dimension "B" (mm)</th> <th>Dimension "C" (mm)</th> </tr> <tr> <th>Standard</th> <th>Limit</th> <th>Standard</th> <th>Limit</th> <th>Limit</th> </tr> </thead> <tbody> <tr> <td>0,5</td> <td>17,5</td> <td>15,8</td> <td>16</td> <td>14,5</td> <td>24</td> </tr> <tr> <td>1</td> <td>22</td> <td>19,8</td> <td>19</td> <td>17</td> <td>29</td> </tr> <tr> <td>1,6</td> <td>26</td> <td>23,4</td> <td>23</td> <td>20</td> <td>35</td> </tr> <tr> <td>3,2</td> <td>36,5</td> <td>32,8</td> <td>34</td> <td>30,5</td> <td>41</td> </tr> <tr> <td>5</td> <td>42</td> <td>37,8</td> <td>35</td> <td>31,5</td> <td>45</td> </tr> <tr> <td>7,5</td> <td>48</td> <td>43,2</td> <td>38</td> <td>34,2</td> <td>47</td> </tr> <tr> <td>10</td> <td>58</td> <td>52,2</td> <td>45</td> <td>40,5</td> <td>52</td> </tr> <tr> <td>15</td> <td>67</td> <td>60,3</td> <td>53</td> <td>47,7</td> <td>59</td> </tr> <tr> <td>20</td> <td>75</td> <td>67,5</td> <td>60</td> <td>54</td> <td>66</td> </tr> </tbody> </table>	Capacity (t)	Dimension "A" (mm)		Dimension "B" (mm)		Dimension "C" (mm)	Standard	Limit	Standard	Limit	Limit	0,5	17,5	15,8	16	14,5	24	1	22	19,8	19	17	29	1,6	26	23,4	23	20	35	3,2	36,5	32,8	34	30,5	41	5	42	37,8	35	31,5	45	7,5	48	43,2	38	34,2	47	10	58	52,2	45	40,5	52	15	67	60,3	53	47,7	59	20	75	67,5	60	54	66	
Capacity (t)	Dimension "A" (mm)			Dimension "B" (mm)		Dimension "C" (mm)																																																														
	Standard	Limit	Standard	Limit	Limit																																																															
0,5	17,5	15,8	16	14,5	24																																																															
1	22	19,8	19	17	29																																																															
1,6	26	23,4	23	20	35																																																															
3,2	36,5	32,8	34	30,5	41																																																															
5	42	37,8	35	31,5	45																																																															
7,5	48	43,2	38	34,2	47																																																															
10	58	52,2	45	40,5	52																																																															
15	67	60,3	53	47,7	59																																																															
20	75	67,5	60	54	66																																																															
5. Chain - elongation - colour marking (applicable for 15 and 20t)	Pitch measuring by slide calliper, measure in place, where the contact with pulley and nut is the most frequent. Visual check.	Dimensions „p“ must not exceed limit values mentioned in the following table. Colour is not visible	If limit criteria are exceeded ask for replacing the chain. Paint the center of the chain with red colour in the length about 600 mm																																																																	

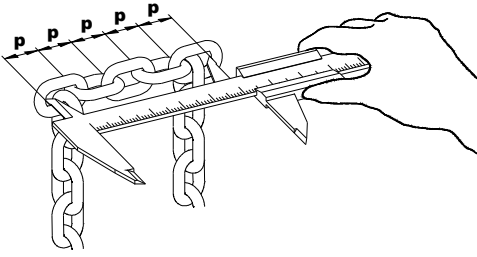

Chain size (d)	Number of measured linksú	Pitch of measured linksú p x 5		Discard limit for d)
		Standart	Limit	
Ø5	5	75	77,3	4,5
Ø7	5	105	108,2	6,3
Ø9	5	135	139,1	8,1
Ø11	5	155	159,7	9,9

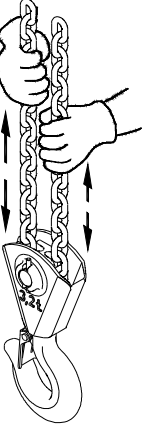
6. Brake - function	Suspend the load equal to nominal lifting capacity; lift it at min. by 250 mm and lower down.	After interrupting the operation, the brake must keep the load in any position of lifting or lowering.	If it does not happen, ask for repairing and adjusting the brake.
7. Anchoring the chain.	Visual check.	The end of the chain is not fastened to the body enough..	Fasten the fixing screw; repair the damaged joint or replace.
8. Pawl - function	Visual check during lifting.	Pawl does not snap to ratchet wheel teeth.	Clean, lubricate or replace the spring.
9. Block sheave rotating (at lifting capacity 7,5t)	Rotate with block sheave by pulling the chain. 	Block sheave does not rotate fluently.	Clean, lubricate or repair.
10. Side plate	Visual check	Visual deformation of slide plates.	Revision of the hoister; putting out of operation
11. Travel of trolley	Visual check	Failure of the condition 6.3.1	Set up the travel.
12. Deformation and wear of crossbeam and load bar	Visual check or check by means of slide calliper	Curved or worn out crossbeam or load bar more than by 10%	Revision of the hoister, discard.

9 TROUBLE-SHOOTING

Situation	Cause	Remedy
1. The chain block does not keep the load.	Brake slips.	Setting the brake or repair according to the chapter „Maintenance“.
2. The chain block lifts hard or fails to lift the load.	(1) The chain block is overloaded. (2) Damaged gearing.	(1) Decrease the weight of load to nominal lifting capacity. (2) Check parts according to the chapter „Maintenance.“
3. The chain has a bad approach, jams.	Damaged or worn chain or nut.	Check the chain or parts according to the „Regular inspection“ or provide repair according to the chapter „Maintenance.“
4. Abnormal sounds come from the chain block.	1) Chain is not lubricated enough. 2) Gear is not lubricated enough. 3) Worn block sheave.	1) Lubricate the chain. 2) Lubricate the gear. 3) Replace the sheave.
5. Inaudible characteristic sound during falling the pawl to claw of ratchet wheel.	Loose of pawl function. Rust, impurities, broken spring.	Clean, replace the spring by new one.
6. Safety latch does not work.	(1) Damaged safety latch. (2) Deformed hook.	(1) Repair the safety latch. (2) Check the hook – see „Daily inspection“.

10 LUBRICATION

10.1 GENERALLY

Remove the old lubricant before the application of a new one. Clean parts by the dissolvent and put the new lubricant. Use the lubricant prescribed by the manufacturer. Use grease: Universal lithium plastic lubricant, water resistant, usable in a minimum range of working temperatures from -20 °C to +50 °C. For example A2, LV2EP. In case of lower temperatures (down to -50 °C) it is necessary to use a special lubricant eg Optitemp LG2.

! WARNING

All lubricants (grease, oil) used in the NEXP version must have an ignition temperature higher than 135 °C. E.g. LV2EP, Optitemp LG2....

10.2 GEARINGS

Dismantle the cover on the opposite side of the chain wheel.
Remove the old lubricant and replace by the new one.

10.3 LOAD CHAIN

! WARNING

The wrong maintenance and inappropriate lubrication of the chain can be a cause of a serious accident.

ALWAYS lubricate the chain 1 x per week or more often according to the exigency of the operation.

ALWAYS lubricate more often in corrosive environment than under normal circumstances (salt water, sea environment, acids, etc.).

ALWAYS use engine oil according to the ISO – VG 46 or VG 48 or their equivalents.

11 MAINTENANCE

11.1 SAFETY PRINCIPLES

! WARNING

Except for the chain replacement and brake adjusting, maintenance, inspections and tests can be carried out only by qualified persons (service organizations) trained in safety and maintenance of these travelling chains blocks.

ALWAYS use only original parts supplied by the manufacturer.

It is not permitted to perform repairs or maintenance in the other way than prescribed by the manufacturers. It concerns especially the forbiddance of using unoriginal spare parts or carrying out modifications on the product without any approval of the manufacturer.

ALWAYS check the function of the travelling chain block after providing the maintenance.

ALWAYS mark the defective or repaired travelling chain block by the suitable label (for example „OUT OF OPERATION“).

NEVER do maintenance when a load is suspended on the chain block.

NEVER use a travelling chain block, which is under repair!

ALWAYS when repairing the paint, it is necessary to observe the total thickness of the paint layer maximum 0,2 mm (original + new paint, or after cleaning the surface new paint, applies to NEXP product design).

11.2 REPLACEMENT OF THE LOAD CHAIN

11.2.1 Single fall chain

Unscrew the bolt on the body of the chain block and remove the free end of the chain (at lifting capacity 3,2t after previous dismantling the cotter pins and sliding out the pin).

Hitch C – link after the last link of the free end – see pic. 11.2.

Provide lowering until the end of the new chain is slipped enough.

Free end of the chain fasten again by the bolt or pin and cotter pins to the body of the chain block.

Fix the coupling with the hook to the other end of the chain. Check, whether the chain is not twisted.

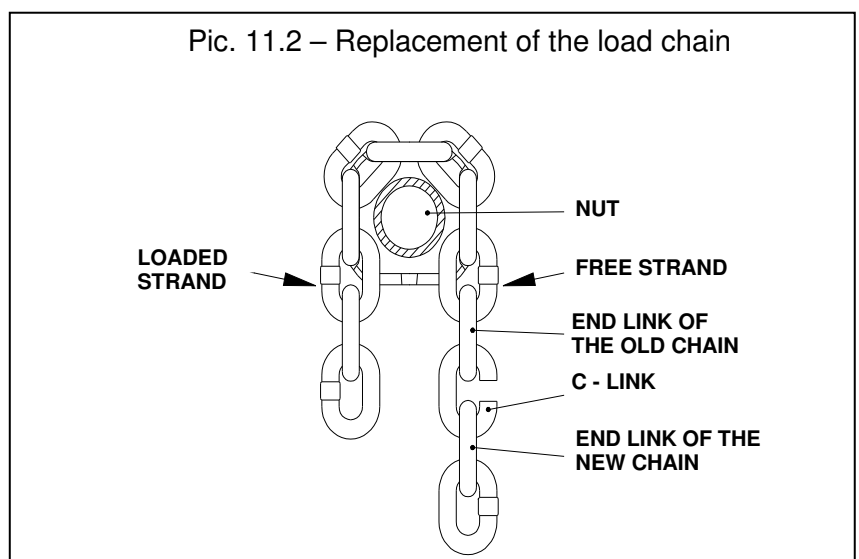

Take off the free end of the chain on the chain block body after previous dismantling of cotter pins and sliding off the pin. Hook C – link and end link of the new chain after the last link of the free strand - see pic. 11.2.

Provide lowering until the end of the new chain is slipped enough. Last link of the free end of the new chain set on the pin and mount again to the chain block body. Ensure the pin properly by the cotter pins. Slipped out end pass through the pulley in the pulley block (lifting capacities 5 and 10t) or pulleys in the pulley block (lifting capacities 5 and 10t) and via pulley in tackle block or coupling beam (only at lifting capacity 10, 15 and 20t), set on the pin and properly ensure by the safety rings. Check, whether the chain is not twisted.

11.3 BRAKE ADJUSTMENT

Remove the cover (1) on the side of the chain wheel together with the hand chain.

Bend off (unlock) the tab of the tab washer (3) and nut (2) tighten slightly. Teeth of segment (4) must be seated in the mesh with teeth of the chain wheel (6).

Thus retightened nut release by 1/6 of a turn, i.e. 60° and ensure with the tab washer (3).

Put on the hand chain on the chain wheel and screw down the cover.

Check the brake with a suitable load.

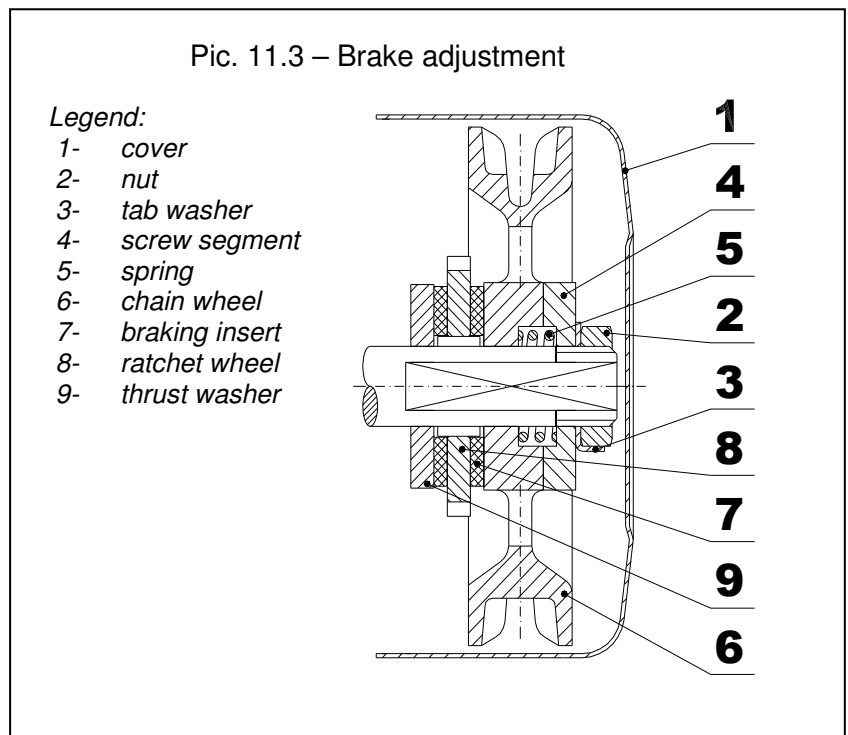

11.4 BEARINGS

Sliding bearings (KU bushings) and rolling bearings are used in the product. The theoretical service life of bearings is several times higher than the theoretical service life of the product. Therefore, they do not require any special maintenance except for cleaning (all) and lubrication (except for roller bearings with a cover) during the regular inspection interval, see 8.1. In the event that the bearing is damaged during disassembly, assembly or due to dirt (sand, rock, dust ...) entering the working space of the bearing, the bearing must be replaced immediately.

11.5 GENERAL INSTRUCTIONS

The following instructions give general important information on dismantling, inspection, repair and assembly. If the travelling chain block was dismantled from any reason, proceed according to the following instructions.

1. The maintenance shall be provided in a clean environment.
2. **NEVER** dismantle the travelling chain block more, than it is necessary for repair.
3. **NEVER** use excessive power during dismantling parts.
4. **NEVER** use heat as a means during dismantling parts, if these parts are determined for further use.
5. Keep the working place clean and free from foreign substances that could get to bearings or other moving elements.
6. If using the vice, always use a suitable insert to protect the surface of the parts.

11.6 CHECK

Check all the dismantled parts, whether they are suitable for further use.

1. Check all gears including the shaft, whether they are not worn out and have no scratches or cracks.
2. Check, whether the treaded parts have undamaged tread.
3. Braking inserts, ratchet wheel and the thrust washer (position 7, 8, 7 and 9 according to the picture 11.3) clean by the wire brush and check their condition.
4. Measure the thickness of braking inserts (see table 11.6)

Table 11.6

Thikness of insert (mm)	Limit (mm)	Wear (mm)
2,5	2	0,5

11.7 REPAIR

Worn out or damaged parts shall be replaced. Small burrs and scratches or other small surface defects remove and smooth by the fine abrasive stone or the abrasive cloth.

11.8 TEST

The loading test with load exceeding lifting capacity by 50% shall be done at all repaired chain blocks by a qualified person to verify the function and chain block brake.

12 PUTTING OUT OF OPERATION – LIQUIDATION

The chain block does not contain any harmful substances; its parts are made of steel and cast iron. After the putting out of operation give it to a firm dealing with disposal of metal waste.

13 RELATED DOCUMENTATION

of Law as amended

EC declaration of conformity

This Instruction Manual was elaborated in accordance with following technical regulations, technical standards and national regulations:

- Ministerial order No.176/2008 of the Coll. of Law as amended (EP and Council directive 2006/42/EC)
- Ministerial order No.116/2016 of the Coll. of Laws as amended (EP and Council directive 2014/34/EU)
- ČSN EN ISO 12100
- ČSN EN 13157+A1
- ČSN EN 1127 - 2
- ČSN EN 1127 - 1
- ČSN EN ISO 80079-36
- ČSN EN ISO 80079-37
- Regulation of CBM (Czech Bureau of Mine) No.22/89 of the Coll. of Laws
- ČSN CLC/TR 60079-32-1

14 FINAL REQUIREMENTS OF THE MANUFACTURER TO THE CUSTOMER

Any changes of the product, eventually usage of unoriginal spare parts can be realized only based on the approval of the manufacturer.

When not observing this condition the producer does not guarantee safety of his product. In this case, any manufacturer's guarantees do not apply to the product.